

WZL™

FULL MAG INDICATOR



CONTENTS



PRODUCT OVERVIEW

WZL™ enables rapid visual and tactile confirmation that the magazine is fully loaded and easy differentiation between magazines with mixed loadouts. When fully loaded with 30 rounds, a black, blue or orange indicator will emerge from the baseplate, allowing you to identify magazines with different rounds, such as ball, tracer, supersonic and subsonic.

Three (3) WZL™ Floor Plates

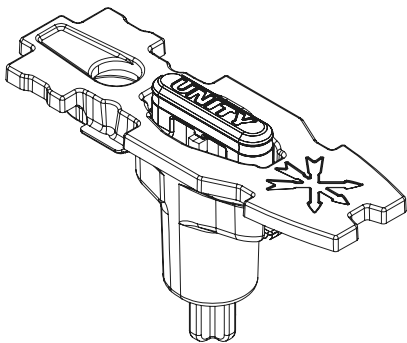



WARNING: ENSURE FIREARM IS UNLOADED

1

Disassemble factory PMAG®. Using a straight edge or bullet tip, depress the floor plate lock tab and slide the factory installed floor plate rearward (for GEN M3™ PMAG®) or forward (for GEN M2™ PMAG®) and off the magazine body.

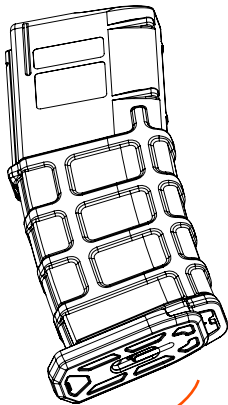
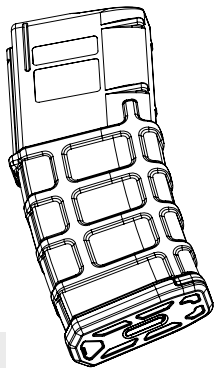

NOTE

The lock plate is under pressure and must be depressed far enough in to unlock the floor plate. Be aware of spring tension when removing the Floor Plate as the spring assembly may rapidly exit the PMAG®. Remove the complete spring assembly from the magazine and set aside for further disassembly.

2

Change floor plate. While holding the spring assembly, rotate the currently installed floor plate until the spring lock tabs clear the last coil of the spring and easily remove. Align the WZL™ onto the last coil of the magazine spring and apply downward pressure until the spring snaps into place over the spring lock tabs.

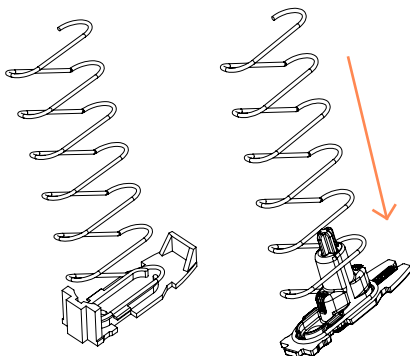

3

Reassemble PMAG®. Re-insert the spring assembly into the PMAG® magazine body, ensuring the follower is oriented correctly prior to insertion. Apply enough pressure on the lock plate until WZL™ can be installed by sliding into the locked position.



WARNING:

FAILURE TO FULLY LOCK FLOOR
PLATE IN PLACE MAY CAUSE SERIOUS
WEAPON FAILURE.



ATTENTION:

CHECK MAGAZINE FUNCTION VIA
LIVE FIRE TEST PRIOR TO
OPERATIONAL USE.

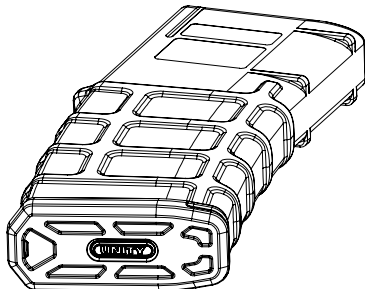

INFO@UNITYTACTICAL.COM

©2024 UNITY Tactical. All Rights Reserved.
Specifications subject to change without notice. PAT: UTIP.CO

