

⚠️ ENSURE FIREARM IS UNLOADED

⚠️ **WARNING:** Over-torquing fasteners can damage your mount and will not be covered by warranty.

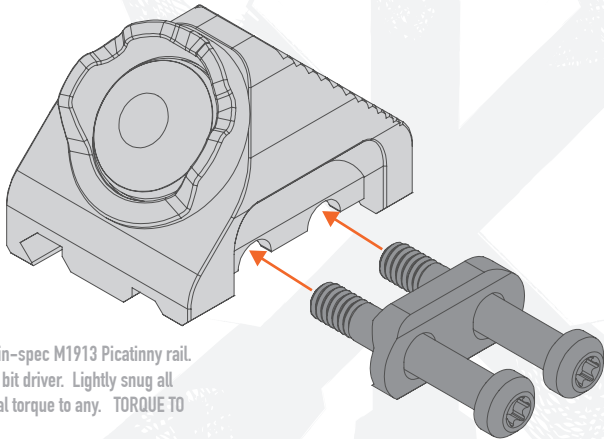

- 1 Install Hot Button™ on an in-spec M1913 Picatinny rail. Secure screws using a T15 bit driver. Lightly snug all screws before applying final torque to any. **TORQUE TO 16 IN-LBS.**
- 2 Route cable from Hot Button™ to light or laser device and fully seat plug in socket. Avoid sharp bends in cable and routing over extreme heat areas and sharp edges.