

FAST™

FTC OMNI



 **UNITY™**

©2018 Unity
All rights reserved.
Unity.com

CONTENTS



PRODUCT OVERVIEW

The FAST™ FTC OMNI magnifier mount positions a variety of magnifiers from various manufacturers at a 2.26" optical centerline from the rail. It employs a simple force-to-overcome mechanism, stowing the magnifier below the optical sight plane and completely within the footprint of the weapon's receiver when not in use.

One (1) FAST™ FTC OMNI

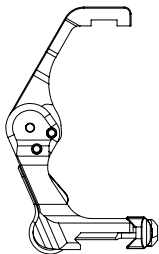

Two (2) 10-32 x 3/8" Magnifier Mounting Screws
for EOTECH®, Trijicon® or Vortex®



One (1) Sig Sauer® JULIET Adapter



Two (2) M4 x 10mm Magnifier Mounting
Screws for Holosun®



Four (4) M3 x 8.5mm Magnifier Mounting
Screws for Sig Sauer®





WARNING: ENSURE FIREARM IS UNLOADED



CAUTION:

OVER-TORQUING FASTENERS CAN DAMAGE YOUR MOUNT AND/OR YOUR OPTIC AND WILL VOID YOUR WARRANTY. USING THREAD LOCKING COMPOUNDS, SUCH AS LOCTITE® OR OTHERS, IS NOT RECOMMENDED AND WILL VOID YOUR WARRANTY.

1

Up-end and seat Magnifier in FAST™ mount arm (do not use shims from OEM magnifier kits). Insert the included two 10-32 x 3/8" Magnifier Mounting Screws in EOTECH®, Trijicon® or Vortex® optics. Insert the included two M4 x 10mm Magnifier Mounting Screws in Holosun™ optics. Insert the included four M3 x 8.5mm Magnifier Mounting Screws and the JULIET Adapter in Sig Sauer® optics. Secure EOTECH®, Trijicon® and Vortex® screws using a T20 bit driver. Secure Holosun™ and Sig Sauer® screws using a T10 bit driver. Lightly snug all screws before applying final torque. **Torque all mounting screws to the specifications recommended by the manufacturer of your magnifier.**

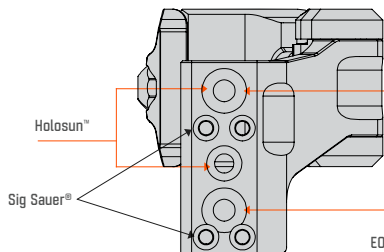

EOTECH®
Trijicon®
Vortex®

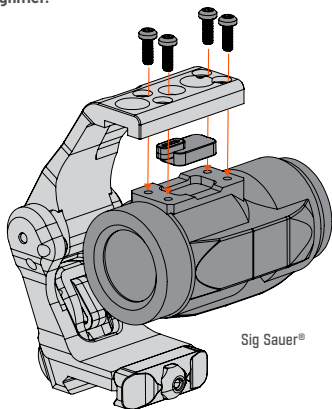

Sig Sauer®

2

The FAST™ FTC OMNI mount uses a force-to-overcome mechanism. Grasp the magnifier body and pivot assembly and pivot downwards to the stowed position. Repeat in reverse to bring the magnifier back into the active position.



NOTE

Do not adjust the Pivot Bolt or disassemble the mount. Doing so will void the warranty.

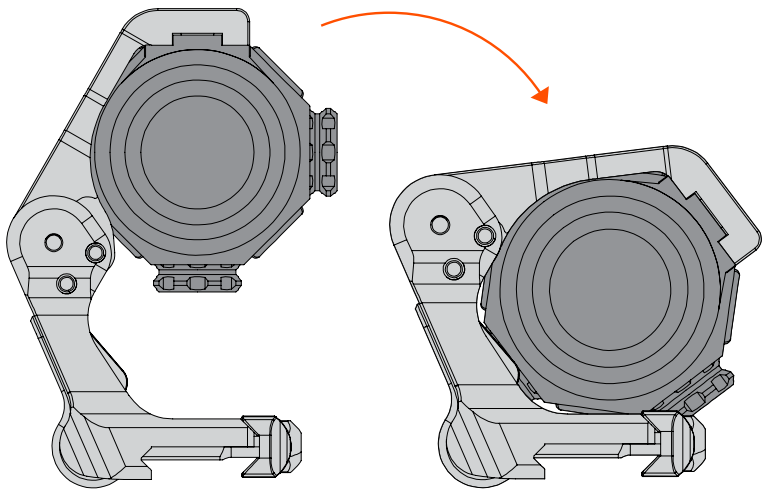

3

Bring the magnifier into the up position. From the inside of the base, depress the safety on the interior of the integrated FAST™ QD Lever. Push outward and the QD Lever will open fully. The QD Lever may need to be held flush with the mount base while depressing the safety.

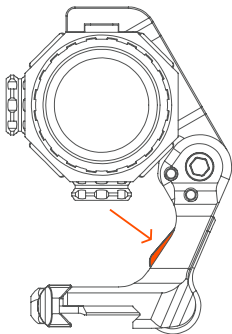

CAUTION:

DO NOT PUSH THE QD LEVER IF THERE IS RESISTANCE. ENSURE THE SAFETY LATCH IS DEPRESSED FULLY OR THE LEVER WILL NOT OPEN. THE QD LEVER MUST BE FULLY CLOSED/FLUSH WITH THE MOUNT BASE BEFORE THE SAFETY CAN BE DEPRESSED.

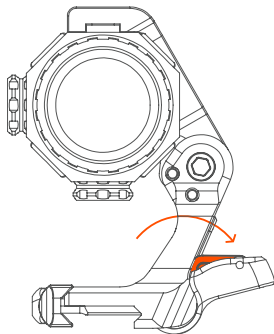

4

To adjust the correct tension of the base onto the M1913 rail, the QD Lever must be in the absolute down/open position. Squeeze the spring tensioned base and rotate the nut clockwise to tension or counter clockwise to loosen.

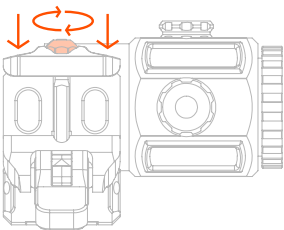

5

Place the magnifier in the desired location on your M1913 Rail. Ensure you seat the side of the base without the QD Lever first. Pull the QD Lever up into the closed position until you feel it snap.

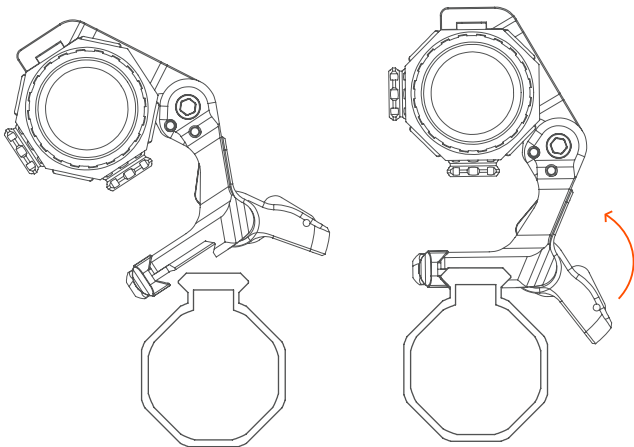

INFO@UNITYTACTICAL.COM

©2025 UNITY Tactical. All Rights Reserved.
Specifications subject to change without notice. PAT: UTIP.CO

